

# AIR EDGER™ FLAT JET INSTALLATION AND MAINTENANCE

## AIR EDGER™ SHIM AND FLOW/FORCE

The Nex Flow Air Edger™ Flat Jet is available with various gap settings using one, two or more shims. Shim sizes are 0.004" (10 Microns), 0.008" (20 Microns) and 0.020" (50 Microns). The greater the gap, the greater is the air consumption and greater is the force.

Shims can be single piece or stacked. Simply remove the two screws holding the body and cap together, insert the desired size and number of shims and reconnect the screws.

## CARE OF THE COMPRESSED AIR SUPPLY

In all applications, NexFlow™ recommends that the compressed air supply be filtered to remove water and oil and to use filters and regulators rated to at least 250 PSIG pressure (17.2 Bar). Recommended filtration for water removal is 0.03 micron. Recommended filtration for oil removal is 25 micron. All filters should have a float type automatic drain.

Filters should be mounted near the Air Edger™ Flat Jet within 10 to 15 feet (3 to 4.6 meters approx.).

## MAINTENANCE

If the unit becomes clogged from contamination simply dismantle, clean and reassemble. Sometimes dirty film can build up at the exit of the Air Edger™ Flat Jet due to the vapor, or smoke or dirt being drawn into the assembly.

Clean the surface with a mild solvent and clean rag. To prevent contaminants from entering into the gap, do the cleaning with a small amount of compressed air passing through the unit.

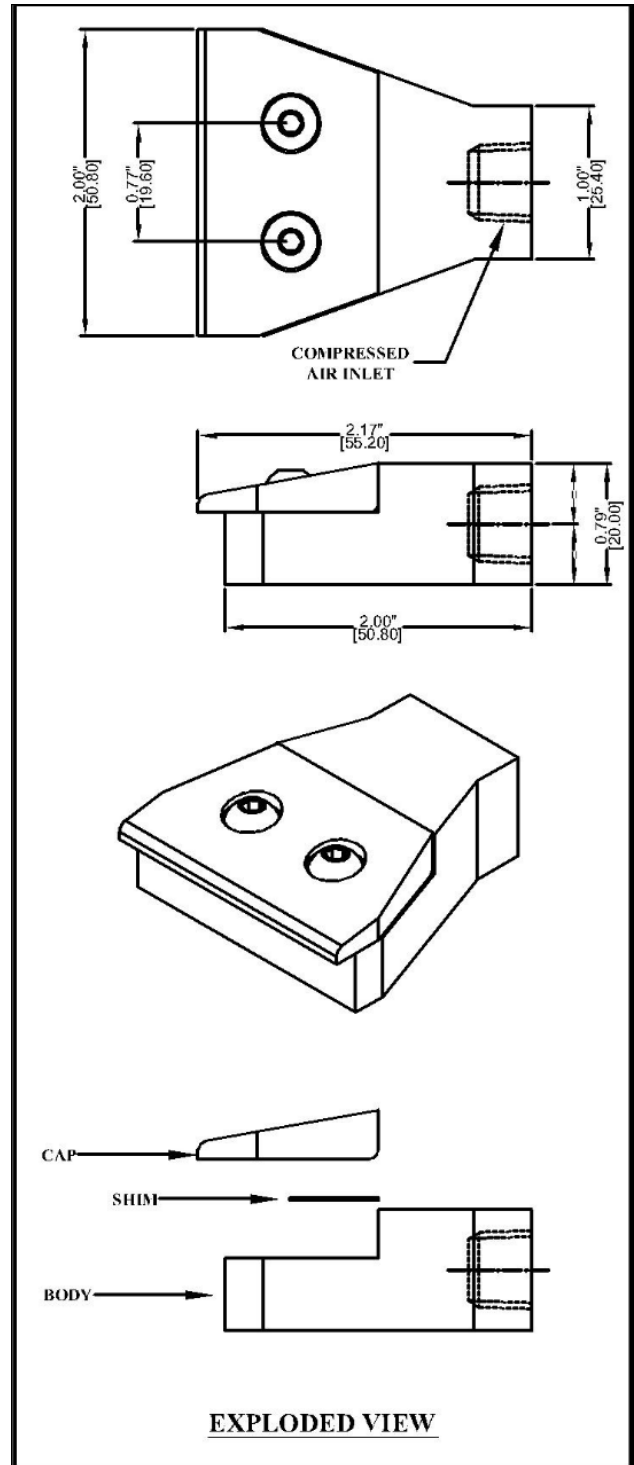

**For Assistance in India, please contact**

**KJN ENTERPRISES**

68A, New Empire Industrial Estate,

Kondivita Lane, J.B. Nagar,

Andheri (E), Mumbai59.

Ph.: 022 – 28342079 / 30888514

Fax: 022 – 30888515

Email: [info@kjnenterprises.com](mailto:info@kjnenterprises.com)

Web Site: [www.kjnenterprises.com](http://www.kjnenterprises.com)



Leading Technology Into The Future  
**NEX FLOW™**  
Technologies Inc.

**For Assistance Worldwide, please contact**

**NEXFLOW AIR PRODUCTS CORP.**

E-mail: [sales@nex-flow.com](mailto:sales@nex-flow.com)

Web site: [www.nex-flow.com](http://www.nex-flow.com)